

RE60 FREE WEIGHT SERIES**RE6001 - SMITH MACHINE****PRODUCT OVERVIEW**

The RE6001 is a high-performance commercial Smith machine engineered for professional strength training. It features a dual-axis precision linear bearing system that ensures exceptionally smooth and stable barbell movement along a fixed vertical path, enhancing both control and safety. The vertical trajectory improves resistance efficiency, making it ideal for exercises such as squats, bench presses, and bent-over rows.

Equipped with 14 barbell positions, the machine accommodates users of varying heights and a wide range of movement patterns. Independent safety stop hooks on both sides are compact and easy to adjust, offering secure training without interfering with barbell starting height—especially useful for exercises that begin from the bottom position, such as deadlifts and squats.

Top and bottom band pegs provide resistance variability: the upper pegs assist with explosive lift-off, while the lower pegs increase end-range load, enabling more effective muscle activation and progressive overload. Each side includes four Olympic plate storage horns, strategically positioned to avoid the lifting zone, ensuring safe and efficient storage without compromising training space.

SPECIFICATIONS & KEY FEATURES

Specifications

Dimension:	2252*1029*2357mm
Net Weight:	208kg
Max Load Capacity:	300kg
Standard Color Scheme:	Gray

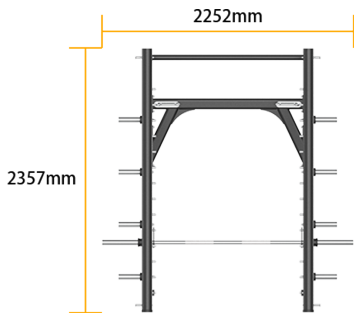

Product Features



Precision Linear Bearing System

Dual-axis vertical guide rods ensure smooth, stable barbell motion, reducing unwanted shaking or jamming for enhanced safety and control.



14 Barbell Positions

Accommodates a wide variety of heights and movement types, offering increased training freedom and versatility.



Independent Safety Stop Hooks

Compact and adjustable design ensures safety while preserving the natural start position of the lift, optimizing performance in squats, deadlifts, and more.



Dual Band Pegs (Top & Bottom)

Upper pegs support lift initiation; lower pegs enhance end-range resistance, delivering full-spectrum muscular stimulation.



Integrated Weight Plate Storage

Four storage horns on each side keep plates organized and out of the lifting zone, improving space efficiency and ease of use.